



Concrete Boom AST-29.4/125 HIGH-TECH series

The new generation of Antonelli booms:

- Structure designed with the latest and advanced calculation method
- High resistance material
- Uniformity of stresses
- Low weight and high stiffness
- Proportional movements and numberless working positions
- Easy maintenance and quick installation



Dwg. No. "10013005 REV.0

CONSTRUCTION:

The structure is composed by a cruciform base which is fastened on the foundations and supports the boom for "free standing". One or more tubular columns are fastened on the support foot. The ladders, leading to the working platform, are mounted on the tubular column.

The boom is assembled to the column by means of the boom pedestal which includes the oil tank and all components for its operation (pump electrical motor ...).

The boom, designed in order to reduce the weight of the components which are moved during the assembly stage, is conceived to obtain safe, reliable, easy and quick mounting and dismantling operations.

This construction is in alloy sheet steel of high mechanical strength, which ensures maximum safety with minimum weight.

The various boom positions are maintained, regardless of the hydraulic control, by special check and lowering control valves, specially produced for this equipment.

The boom movements, with optimum rotation ranges (see technical data and diagrams) have a wide range of adaptation, allowing them to reach any position with the boom's own radius of operation.

FREE STANDING SYSTEM:

It is prepared with X foot and tubular columns having different measurements (length 4-6-10 m) to reach the max. height of 20 m, column head included.

The ladder provided allows to easily enter the working platform mounted on the upper part of the column.

The quick mounting device, mounted between the tubular column head and the boom pedestal, allows a quickly assembly.

CLIMBING SYSTEM:

By using the floors as support, the structure, composed by the boom and the tubular column, climbs through openings obtained in the floors and it is secured to these latter by means of suitable shaft frames.

Besides the components for the "free standing", the system also includes the floor frames to be secured on three floors, the climbing cylinders and the fastening bolts.

CONCRETE PIPELINE:

The concrete conveyor pipeline, in metal throughout, is constructed from cast bends with differentiated thickness (**DIN standard**) and straight pipes connected by means of lever couplings, allowing extremely quick dismantling.

CONTROLS:

Boom movements are obtained using manual controls at the base of the turret; all the functions found in this control unit are also available on a button board with power lead for remote control.

In any case all boom movements have proportional control. The control unit consists of an airtight, thermostable box in insulating, shock-proof material, with circular contact switches allowing more than one movement to be obtained simultaneously.

The emergency pushbutton device instantaneously prevents all operation of the equipment, whether from the directional control valve or from the button board.

The specifications and technical data given here are purely guideline and are not binding.

Modifications may be made without notice.

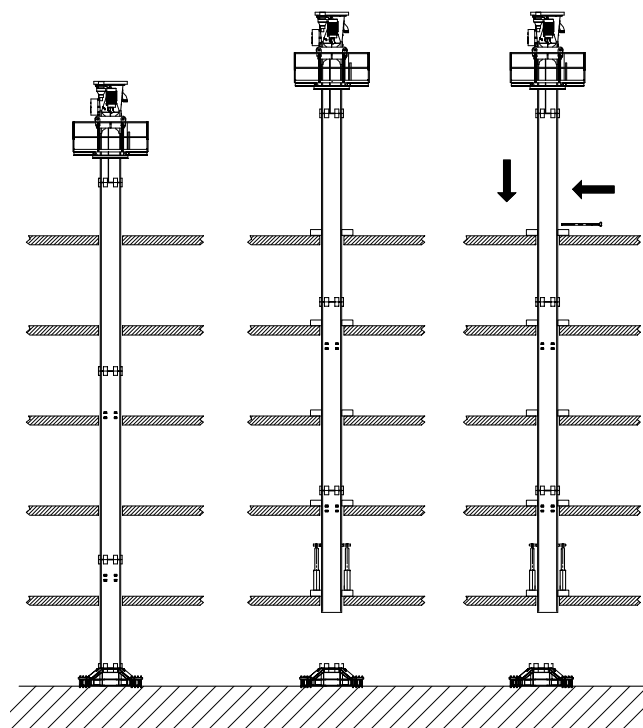
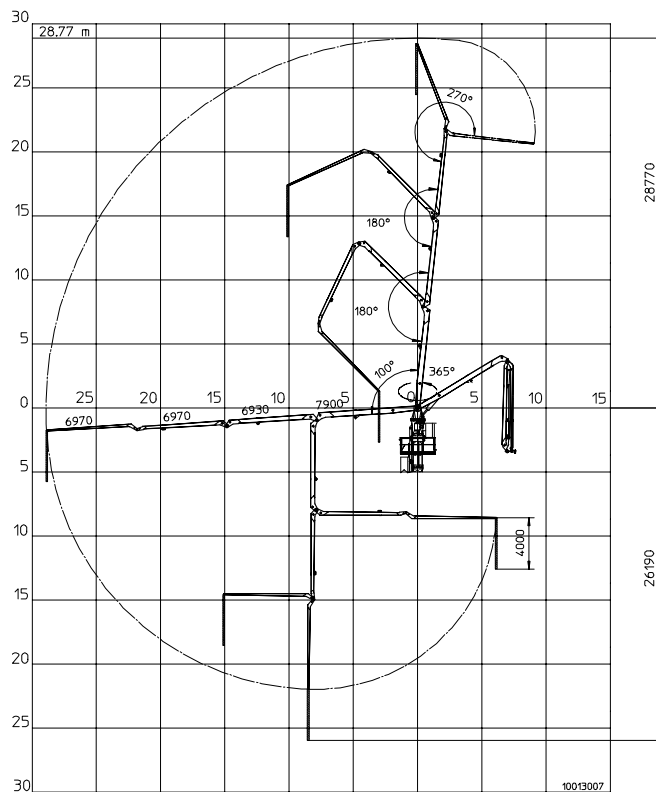
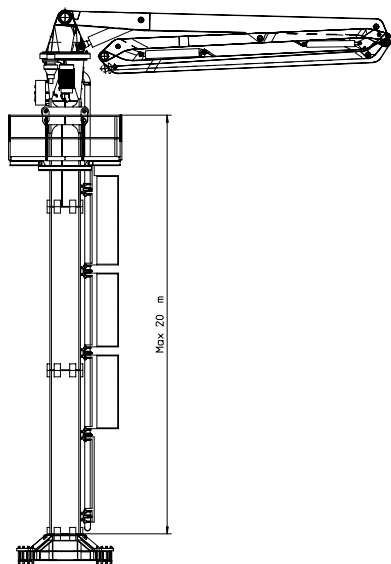

TECHNICAL DATA

AST-29/125

CONCRETE PIPELINE DIAMETER	125 mm	WEIGHT OF BOOM PEDESTAL AND BOOM	7550 Kg
HORIZONTAL REACH/VERTICAL REACH	28,77 m	1ST ELEMENT ROTATION	100°
REACH DEPTH	26,19 m	2ND ELEMENT ROTATION	180°
END HOSE	4 m	3RD ELEMENT ROTATION	180°
SLEWING RANGE	370°	4TH ELEMENT ROTATION	270°
HYDR. WORKING PRESSURE	320 bar	HYDR. PUMP OIL FLOW	28 l/min
FREE STANDING TUBULAR COLUMN LENGTH	20 m	ELECTRICAL SYSTEM	12-24 V.
STATIC OVERTURNING MOMENT	66142 Kgm	INSTALLED POWER	18,5 Kw

ANTONELLI s.r.l.

Via Malpasso 1447/Int. 2 - 47842 S. Giovanni in Marignano (Rn) - Italy

Tel: 0039 541955258 Fax: 0039 541957103

e-mail: antonelli@antonelli.it